



Dataloggers

Recorder of

temperature
humidity
current
voltage
pulses
events

Case of sensor is made of ABS which is very resistant to mechanical damage. Sealing lid protects electronics from dust and splashing water - IP67.

Long battery life - up to 7 years.

Recorders with integrated sensors for measuring temperature and humidity.

Recorders with inputs for external temperature probes.



Recorders with input for dry contact and the two-state voltage signal. With input for pulses counting.



• high quality, accurate and stable sensors • traceable calibration certificate in accordance with EN ISO/IEC 17025



Applications

COMET dataloggers are intended to measure physical and electrical quantities. Measured values are recorded in the nonvolatile memory. Alarm limits can be set for individual measured variables. In the case these limits are exceeded, the unit evaluates this situation as critical and indicates the alarm on the display. The DATALOGGER can also send alarm information to a user's email address or as a text message when the device is connected to the Internet or GSM networks.

All datalogger settings are performed by using a computer software and can be password-protected. The data recorder can be switched on and off by magnet (this possibility can be disabled in configuration), or it can be automatically turned on the set day and time.

MEASUREMENT

Temperature * Humidity * Current * Voltage * Pulses * Events

DATALOGGERS COMET measure physical parameters such as TEMPERATURE, HUMIDITY and DEW POINT. Some models have analog input for measuring DC CURRENT or DC VOLTAGE. These allow to measure other physical quantities with third party sensors. Comet system produces also two-state recorders for monitoring the functions of the machine, running of engine, door open / closed, to control technology procedures, etc. These two-state recorders are also available in combination with the measurement above variables, as well as in combination with PULSE counter for monitoring of water, gas and electricity consumption.

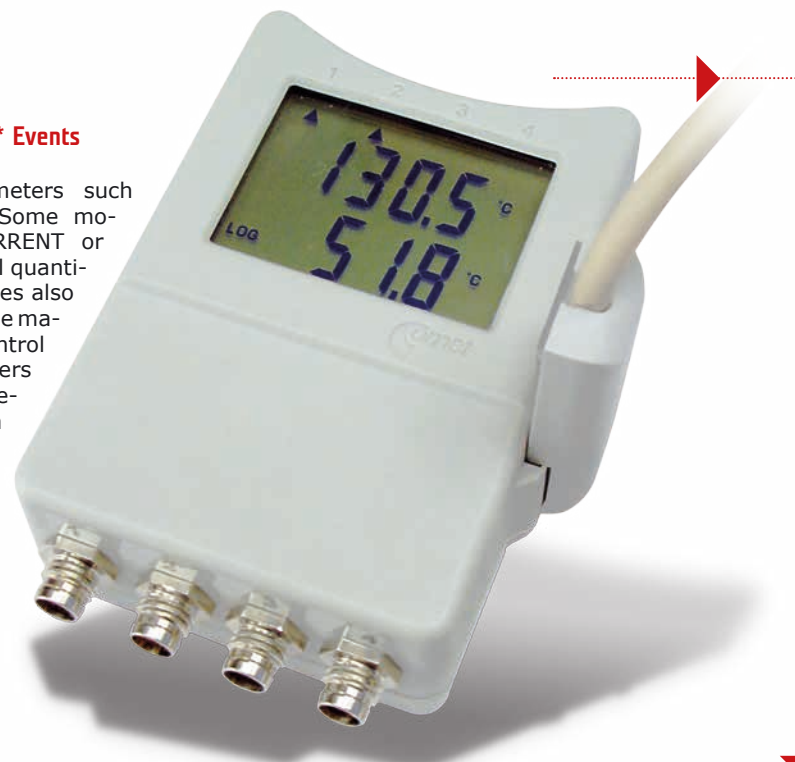

RECORD

The current measured values are stored at preset intervals from 10 seconds to 24 hours. You can store up to 32 000 values. Logging mode can be adjusted as non-cyclic, when logging stops after filling the memory, or cyclic, when the oldest recorded values are overwritten by new ones after the memory is full. Further, the recording can be set to run only when the measured value is outside preset alarm limits. The datalogger can also record MIN / MAX values.

ALARM INDICATION

For each measurement channel can be set upper and lower limits. In case the limits are exceeded an alarm is indicated as the value blinking on the display. You can select continuous alarm mode when the alarm is active only if the critical situation persists, or memory mode when an alarm is still indicated after measured conditions return to normal.

In the event of an alarm the LAN adapter sends a trap message or an e-mail to the user-defined e-mail addresses. E-mail and warning trap can be also sent in case the logger memory occupation reach 90% and 100%, when the battery voltage drops, or when communication error between the logger and LAN adapter occurs. The above mentioned applies for the alarm SMS if the datalogger is connected with a GSM modem.

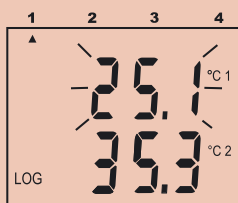

DATA ANALYSIS

The recorded data can be transferred to a personal computer in several ways for further analysis. USB or RS232 communication adapters can be used for short distances, it is necessary to bring the logger to the PC. If it is necessary to download data on the place where logger is mounted the data can be stored in a tablet or smart phone using the Android app. The measured data can be also accessed remotely via a LAN adapter (internet) or GSM modem.

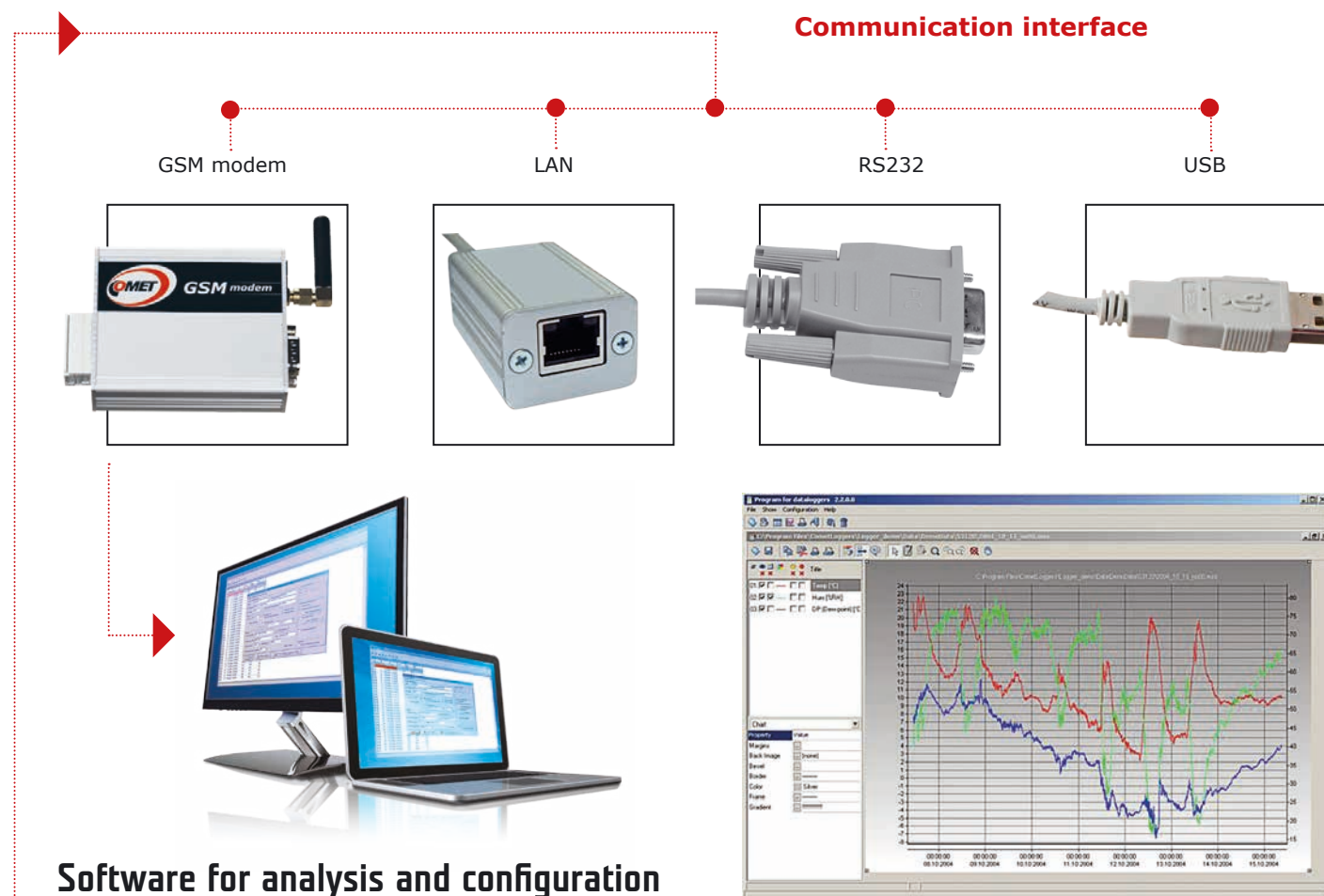

Software for analysis and configuration

Values obtained from a single device can be displayed in the form of a table or graph, data can be printed or exported to dbf or txt format for further processing of spreadsheet software.

Data from a larger amount of dataloggers or other COMET devices can be collected and analysed in Comet Database. Data from all units can be clearly displayed in one table or chart. Comet Database requires database server Microsoft SQL.

What Comet Database offers?

- » comparing data from a larger number of devices
- » data storage
- » simple and clear access to the measurement values
- » data access for other users on the network
- » user management / access rights
- » presentation of data in table and graph
- » compatibility with all COMET devices and third-party devices



Temperature recorders are designed for monitoring of the temperature in standard applications such as monitoring temperature during transport, in warehouses, museums, galleries, etc. The data logger is also very durable and has a high protection against moisture, so it is suitable for usage in extreme conditions. They can be placed directly in the refrigerators or freezers.

Dataloggers demonstrated their toughness during long-term monitoring of climate in caves. Except measurement accuracy and high durability, this application needed extra emphasis on battery life which reached up to 7 years.

Dataloggers are produced in several versions. There is an option with internal sensors, or an option with inputs for connecting up to four temperature probes for measuring in the temperature range -90°C to +260°C.

Datalogger is supplied with traceable calibration certificate in accordance with EN ISO/IEC 17025.

Comet recorders with built-in printer are described in a catalog Solutions for temperature record during transport.



Dataloggers are certificated for monitoring of goods during transport. TÜV SÜD certified to conform to EN 12830, Class 1 and EN 13486, Class 1 for the transport of food.



Long-term monitoring of climate in one of the most important caves of the Slovak Karst.

S0110



Monitoring of critical conditions for storage of drugs with the possibility of sending alarm SMS texts.

thermometers - MODEL	R0110	R0110E	S0110E	S0110	S0122	S0111	S0121	S0141
temperature range	-40°C to +80°C	-30°C to +70°C		-90°C to +260°C				
internal temperature sensor	✓	✓	✓	✓	✓	x	x	x
number of inputs for ext. temperature probe*	-				1	1	2	4
accuracy of internal sensor	±0.4°C	±0.6°C for T < +30°C ±0.8°C for T > +30°C		±0.4°C	±0.4°C	-		
display	x	x	✓	✓	✓	✓	✓	✓
typical battery life	7 years	6 years						5 years
protection class	IP67							

*accuracy of inputs for ext. sensors
±0.2°C from -50°C to +100°C;
±0.4% of temperature T < -50°C;
±0.2% of temperature T > +100°C

Temperature dataloggers combined with two-state inputs S0841 and S0842, or inputs for analog signal S0541 are on other pages of this catalogue.

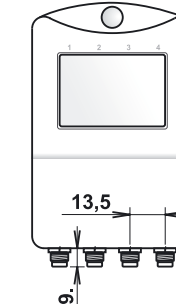
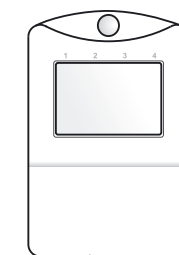
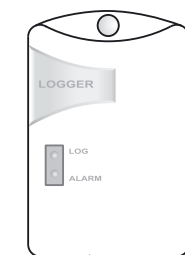

Number of inputs for external temperature probes differ depending on type. See table above.

EXTERNAL TEMPERATURE PROBES

Temperature probes on the cable are designed to measure the temperature in specific applications. Probes are supplied in lengths of 1, 2, 5 and 10 meters. To maintain high accuracy measurements it is not recommended to use probes with lengths greater than 20 meters. Probes are manufactured in accuracy of class A, unless stated otherwise.

Fast accurate air probe with fast response time without protection against moisture.

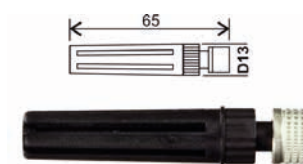

200-80/E
(-30°C to +80°C)

Multi-purpose watertight probe with IP67.

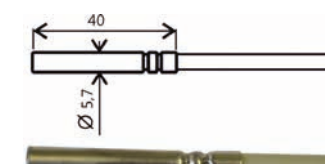

Pt1000TG8/E
(-80°C to +200°C)

Universal temperature watertight probe with IP68 for long-term monitoring of temperature in the liquid.

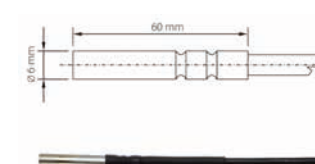

Pt1000TG68/E
(-80°C to +200°C)

Inexpensive probe with plastic housing, slow response and with IP67.

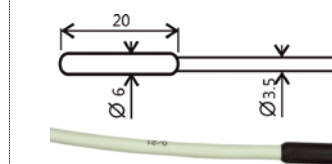

Pt1000TR160/E
(-30°C to +80°C)

Strap-on probe for pipe mounting and flat surfaces. Class of protection - IP65.



PTS350A/E
(-30°C to +130°C)

Brass probe for surface temperature measurements. Probe is not resistant to moisture.

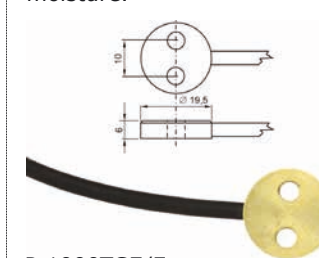

Pt1000TG7/E
(-30°C to +200°C)

Other probes are available on the website www.cometsystem.com

Low cost multi-purpose watertight (IP67) probe.

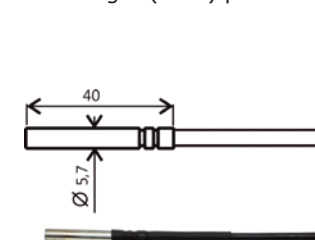

Pt100TGL40/E
(-30°C to +80°C)

Hand-held pointed tip probe for food industry with teflon handle and silicon cable. Class of protection - IP67.

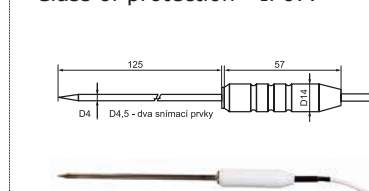

2061-200/E
(-30°C to +200°C)



Thermometer hygrometer datalogger

The instruments are designed for measuring and recording of the ambient temperature, relative humidity and the dew point. Measuring temperature and humidity sensors are integrated into the body of device or on a cable length of 1, 2 and 4 meters. There is also an economical version of the thermometer hygrometer datalogger S3120E for undemanding applications.



Climate measurement for needs of avalanche prevention.



S3120



thermometer hygrometer datalogger	R3120	S3120	S3120E	S3631	R3121	S3121
relative humidity range	0 to 100 %					
temperature range	-30°C to +80°C	-30°C to +70°C	-90°C to +260°C **	-30°C to +105°C		
internal temperature, humidity sensor	✓	✓	✓	✓	x	x
humidity and temperature sensor on the cable	x	x	x	x	✓	✓
number of inputs for ext. temperature probe*				1	-	
relative humidity accuracy***	±2.5% RH	±2.5% RH	±3% RH	±2.5% RH	±2.5% RH	±2.5% RH
dew point accuracy ****	±1.5°C	±1.5°C	±2°C	±1.5°C	±1.5°C	±1.5°C
temperature accuracy	±0.4°C	±0.4°C	±0.6°C for T < +30°C ±0.8°C for T > +30°C		±0.4°C	±0.4°C
with display	x	✓	✓	✓	x	✓
typical battery life	7 years	6 years			7 years	6 years
class of protection of case with electronics / sensors	IP67 / IP30		IP30/ IP30	IP67 / IP30	IP67 / IP40	

RH - relative humidity

* accuracy of inputs for ext. sensors
±0.2°C from -50°C to +100°C;
± 0.4% of the temperature T<-50°C;
± 0.2% of the temperature T>+100°C
** Maximum range for external probe
*** In the range from 5 to 95% at 23°C
**** At ambient temperature T<25°C
and RH>30%

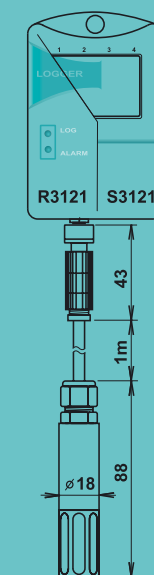
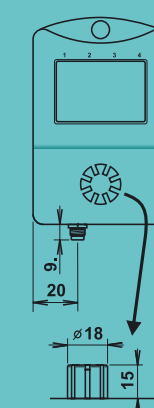
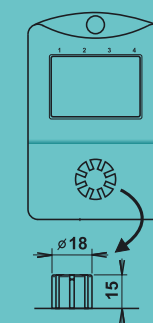
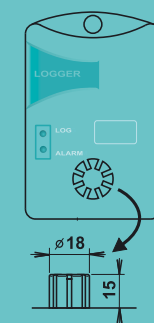

Temperature hygrometer data logger with two inputs for analog signal is available at the page 8.

External temperature probes can be found at the page 5.

ACCESSORIES FOR CALIBRATION AND ADJUSTMENT

The verification of the accuracy of measurement (calibration) and possibly the new settings (adjustment) of the instruments measuring the relative humidity can be done by using special accessories which can replace prescribed high cost special device for generating a relative humidity (calibration chamber).



HM023 - set of 5 humidity standards 10% RH with 5 application pads.

HM024 - set of 5 humidity standards 80% RH with 5 application pads.



MD046 - air-tight vessel for adjustment and calibration of humidity.



SENSOR COVERS FOR IMPROVED PROTECTION



F5300 - teflon sensor cover with increased resistance against splashing water. Cover is not suitable for applications with risk of condensation. Filtering ability 0.025mm.

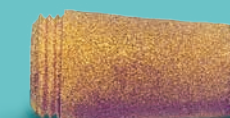

F0000 - sintered bronze sensor cover for moderate aggressive environments. Filtering ability 0.025mm.



F5200B - sensor cover with filter from stainless steel mesh, suitable for moderately dusty environment. Filtering ability 0.025 mm.

F5200 - grey version of sensor cover.



F8000 - multiplate meteorological shelter for humidity and temperature dataloggers. Solar radiation shield for devices with T+RH probe.



Current and voltage dataloggers

Voltage and current dataloggers are designed to measure and record signals from up to two sensors with current output 0 - 20 mA or voltage output of 0 - 5 V (possibly to order 0 - 10V). At the same time you can record the status of the binary signal - voltage or from dry contact (does not apply to models S0541 and S3541).

Values of voltage and current can be assigned a value and physical unit just measured quantity. The datalogger can be controlled (turned on and off) by external binary signal. This feature is not available for loggers S0541 and S3541 however, these can additionally measure temperature and humidity.

Datalogger is connected to the output of the sensor with shielded cable and with a connection adapter (model S0541 uses ELKA connector). For better class of protection it is recommended to use waterproof adapter K0921.

The connection diagram is illustrative. Specific diagram for the particular model is in the manual, which is available on www.cometssystem.com

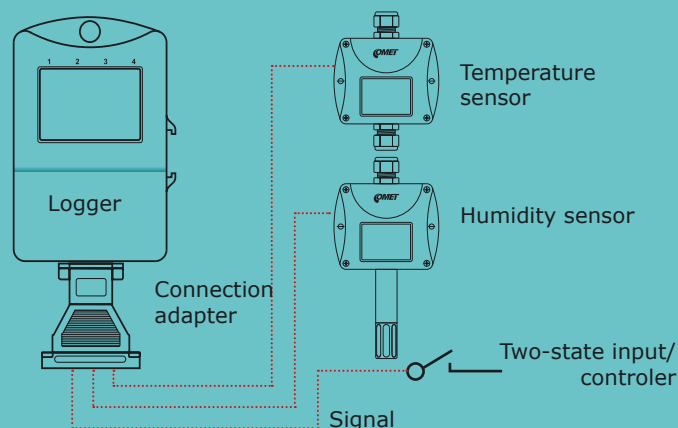

Adapter K0945 - Sensors connected to the datalogger may be powered directly from the adapter K0945.

K0921 - watertight connector for signal connection. Class of protection is IP67.



S6021

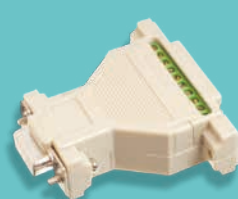

Dataloggers with pulse and two-state inputs

The devices are designed for monitoring the functions of the machine, running of engine, door open / closed, to control technology procedures, etc. It is possible to monitor two-state signal (model S7841) or the number of pulses (model S7021).

Value of pulse counter can be also programmatically assigned to a physical unit measured quantity. Dataloggers S0841 and S0842 have two inputs monitoring binary signal and in addition inputs for connecting temperature probes Pt1000.



Datalogger S7021 reads and records data from electrometer.

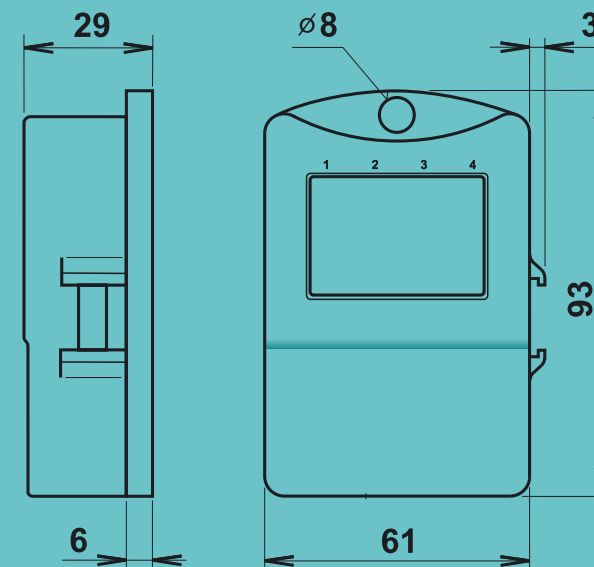

current and voltage datalogger	S6021	S5021	S0541	S3541	S5141
current input	2				
voltage input	-	2	2	2	3
number of inputs for ext. temperature probe*			2		
internal temperature, humidity sensor		x		✓	x
internal temperature sensor			x		✓
two-state input from dry contact or a voltage signal	✓	✓	x	x	
accuracy	± 0.2% of range from 0.01V to 5V, respectively. from 0.2 mA to 20 mA				
low voltage level (L) of binary input	0 to + 0.2V, maximum input current 3 uA				
high voltage level (H) of binary input	+3.0 to + 30V, maximum input current 100 nA				
typical battery life	6 years		5 years	7 years	7 years
class of protection of case with electronics / sensors	IP67 / -		IP67 / IP67	IP67 / IP30	IP67 / IP20

*accuracy of inputs for ext. sensors
 ±0.2°C from -50°C to +100°C;
 ±0.4% of temperature T < -50°C;
 ±0.2% of temperature T > +100°C
 (total temperature range of input is -90°C to +260°C)

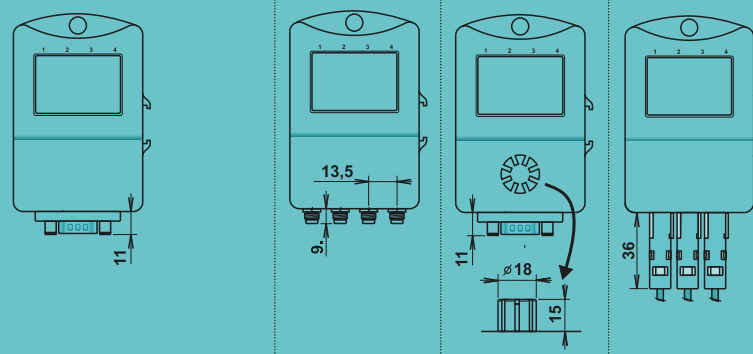

pulse and two-state inputs dataloggers	S0841	S0842	S7021	S7841
pulse counter from dry contact or voltage signal	-	-	1	-
two-state input from dry contact	2	1	1	4**
two-state input from voltage signal	-	-		
number of inputs for ext. temperature probe*	2	3	-	-
low voltage level of two-state input	-	-	0 to + 0.2V, current from input is max 3 uA	
high voltage level of two-state input	-	-	+3.0 to + 30V; maximum current to input is 100 nA	
class of protection of case with electronics / sensors	IP67			IP20

*accuracy of inputs for ext. sensors
 ±0.2°C from -50°C to +100°C;
 ±0.4% of temperature T < -50°C;
 ±0.2% of temperature T > +100°C
 (total temperature range of input is -90°C to +260°C)

** max. 20 changes on all inputs in time interval of 10 sec.

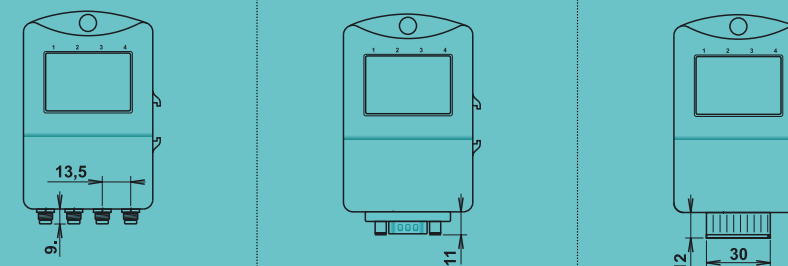



LP004 - START / STOP magnet for datalogger starting and for switching display on/off and for resetting MIN / MAX values. These all functions can be set up in datalogger via software SWR001.



LP003 -USB adapter for communication with personal computer via USB port.



LP012 - COM adapter for communication with personal computer via RS232 serial port.



LP005 - LAN adapter for communication via Ethernet, including the power adapter. Cable length of 0.5 m. Class of protection - IP65.

LP005-5 - LAN adapter for communication via Ethernet, including the power adapter. Cable length of 5 m. Class of protection - IP65.

MOUNTING ACCESSORIES



MP036 - wall holder for GPRS modem.

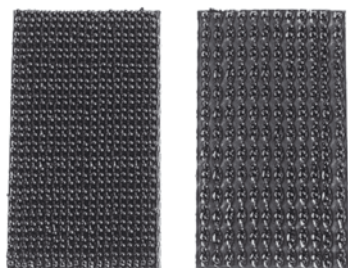

MD036 - Dual Lock - Adhesive Industry hook and loop fastener for easy installation.



MP037 - DIN Rail 35mm holder for GPRS modem.



F9000 - wall holder secure datalogger against unauthorized removal. Standard key - 3 pieces.

SPARE LITHIUM BATTERY



A4203 - 3.6 V, size AA.

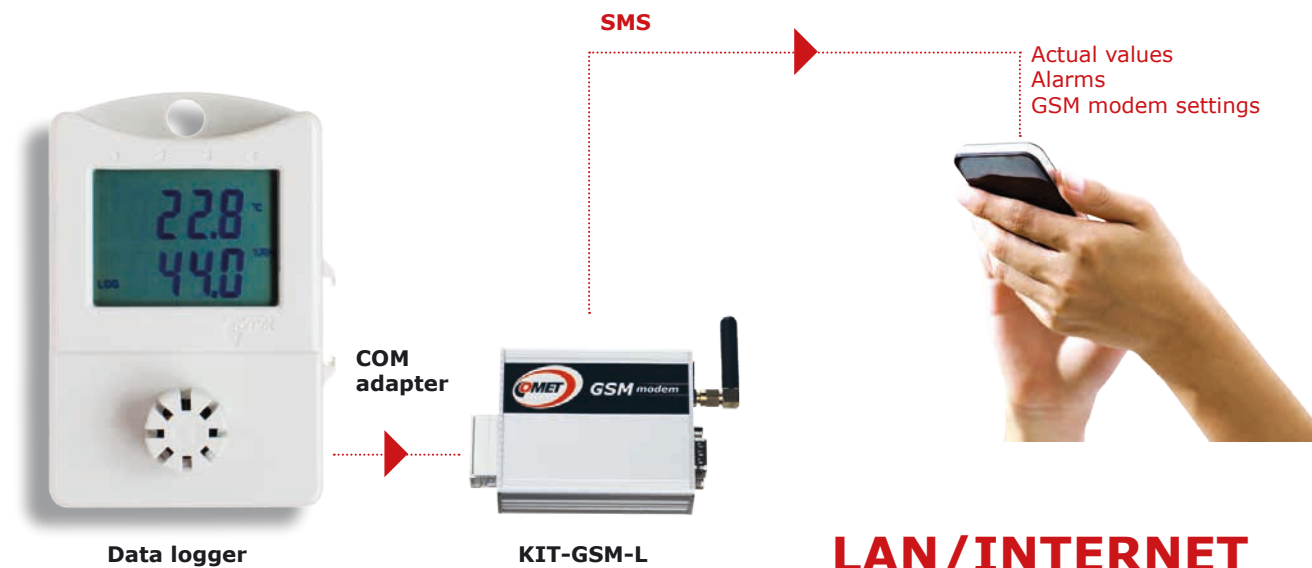

Data logger

KIT-GSM-L

LAN/INTERNET



SLU302 - M2MTalk server service for remote communication with the datalogger including data downloading, setting data logger. If this service is used, GPRS must be activated on your SIM card. Method and amount of payment for this service are determined by valid trading conditions.

M2M GPRS



Comet software for datalogger SWR001



Comet software for datalogger SWR001



Comet software for datalogger SWR001



KIT-GSM-L - set for GSM communication.

- data download from datalogger
- actual values reading
- dataloggers setting
- GSM modem setting

A complete solution for monitoring temperatures during transport

	G0221E	G0241	G0841	G0841W	G0841M	G0841MW
measuring temperature range:	-90 to +260°C					
accuracy of the input without probe:	±0.2°C					
logging interval:	user selectable from 1 minute to 60 minutes					
outdoor usage:	x	x	✓	✓	✓	✓
measured signals :	2xT	2xT + 2xcontact	2xT + 2xcontact	2xT + 2xcontact	2xT + 2xcontact	2xT + 2xcontact
output for GPRS modem:	x	✓	✓	✓	x	x
built-In GPRS mode:	x	x	x	x	✓	✓
wireless alarm unit for driver's cabin:	x	x	x	✓	x	✓
power:	9 to 32Vdc, protected against alternator load shedding+internal Lithium battery					
class of protection:	IP20			IP65		



- » recorders with up to four inputs and built-in printer for direct printing
- » complies with EN 12830, class 1 and EN 13486, class 1 for the transport of food - a calibration certificate included »
- » signalization of crossing temperatures - LED, display, sound »
- » transfer of recorded data to PC via USB



WUNTRONIC

Mess-, Steuer-und Regelgeräte GmbH

Hepstrasse 30, D-80995 Munich, Germany.

Phone: +49 (89) 313 30 07

Fax: +49 (89) 314 67 06

E-Mail: wuntronic@wuntronic.de

Internet: www.wuntronic.de